

PRODUCT DATASHEET

DP HOUSING EM 1500 P 2XLAMP IP65

DAMP PROOF HOUSING EMERGENCY | Damp-proof luminaire for emergency lighting application



Areas of application

- Parking lots, warehouses, production areas
- Emergency lighting for single battery systems
- Dimmable installations
- Car parks and underpasses
- Garages

Product benefits

- Easy and quick installation
- Prewired for easy installation of LED TUBE T8 EXTERNAL SYSTEM
- Toolless installation
- Robust housing
- Sustainable solution thanks to exchangeable light sources
- 5 years guarantee

Product features

- Luminaire housing, available for 1 or 2 T8 LED tubes
- Dimmable EXTERNAL SYSTEM Driver, Emergency unit and Battery are already installed
- Suitable for LEDVANCE LED TUBE T8 EXTERNAL SYSTEM
- DALI 2.0 interface for light management system integration
- Integrated electrical fuse
- Type of protection: IP65



TECHNICAL DATA

Electrical data

Nominal voltage	220...240 V
Mains frequency	50...60 Hz
Protection class	I
Operating mode	Integrated LED driver
Dimming interface	DALI-2

Photometrical data

Flickering metric (Pst LM)	< 1
Stroboscope effect metric (SVM)	< 0.4

Dimensions & Weight

Length	1585.00 mm
Width	95.00 mm
Height	70.00 mm
Product weight	1677.00 g

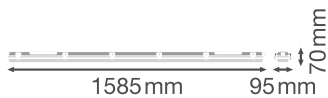

DP HOUSING 1500 P 2XLAMP
IP65

Materials & Colors

Product color	Gray
Housing color	Gray
RAL Color (most similar)	RAL 7040
Body material	Polycarbonate (PC)
Cover material	Polycarbonate (PC)

Light emitting surface material	Polycarbonate (PC)
Glow Wire Test according to IEC 60695-2-12	850 °C
Mercury content	0.0 mg

Application & Mounting

Ambient temperature range	+5...+40 °C
Temperature range at storage	-20...+80 °C
Type of connection	Screwless terminal, 5-Pole (L, N, PE, DA+, DA-)
Type of protection	IP65
Protection class IK (shock resistance)	IK08
Dimmable	Yes
Type of dimming	DALI-2
Mounting type	Surface
Mounting location	Ceiling
Application environment	Indoor
With light source	No
Replaceable light source	No
Holder designation	G13

Control gear

ECG - Output ripple current	≤ 5 %
-----------------------------	-------

BATTERY

Type of Battery	LiFePO4
Battery size [GMS]	Others
Nominal voltage of battery	3.2 V
Battery charging time	>12 h

Emergency lighting

Area of emergency application	Anti-panic lighting / Escape route lighting
Type of emergency light operation	Maintained
Type of emergency operation test	Automatic
Wattage in emergency operation mode	3,0 W
Luminous flux in emergency operation mode	320 lm
Battery life in emergency operation mode	3 h

Certificates & Standards

Standards	CE / TÜV Rheinland / EAC / UKCA
Luminaire with limited surface temperature, "D sign"	No
Ball shot safe	No





Additional product data



Product remark	When used in very cold applications as in cold storage, a special membrane might be required to ensure lifetime
----------------	---

EQUIPMENT / ACCESSORIES

– Stainless steel clamps and M20 cable gland included

DOWNLOAD DATA

Documents and certificates		Document name
	User instruction / safety instructions	UI DP HOUSING EM
	Legal information	LI DP HOUSING EM
	Legal information	Informationstext 18 Abs 4 ElektroG
	Declarations of conformity	CE Declaration DP HOUSING EM
	Declarations of conformity UKCA	UKCA Declaration DP HOUSING EM

CAD/BIM files		Document name
	BIM Revit 3D	Damp Proof Housing G3
	CAD STEP 3D	DP HOUSING G3 2 1500

Tender texts		Document name
	Tender documents	DAMP PROOF HOUSING EMERGENCY 1500 P 2XLAMP IP65-EN

LOGISTICAL DATA

Product code	Packaging unit (Pieces/Unit)	Dimensions (length x width x height)	Gross weight	Volume
4099854148941	Folding box 1	1,572 mm x 98 mm x 75 mm	1876.00 g	11.55 dm ³
4099854246098	Shipping box 6	1,592 mm x 208 mm x 237 mm	12642.00 g	78.48 dm ³

The mentioned product code describes the smallest quantity unit which can be ordered. One shipping unit can contain one or more single products. When placing an order, for the quantity please enter single or multiples of a shipping unit.

ADDITIONAL CATALOG INFORMATION

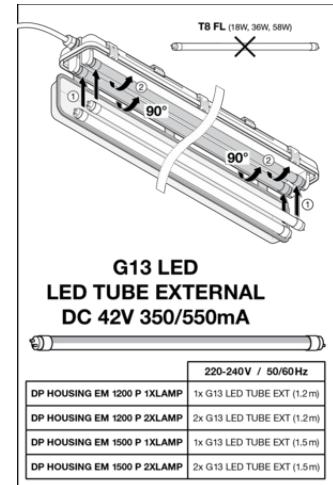
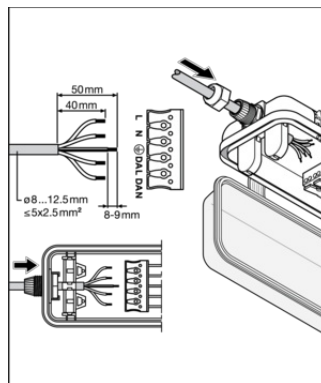
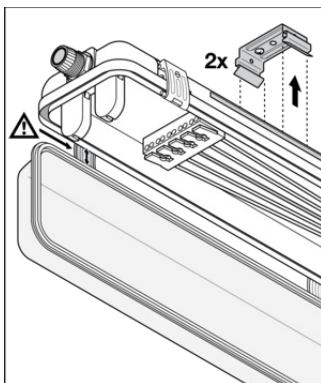

Test ¹⁾		
Initialization ¹⁾	≥ 48h Normal	Automatic ²⁾
Daily check of Control LED ³⁾		Green ⁴⁾
Monthly/Weekly functional test ¹⁾ (EN 50172)	30s	Automatic test once every 7 days ¹⁾
Yearly duration test ¹⁾ (EN 50172)	[3H]	Automatic test once every 12 weeks ²⁾

References / Links

- For Guarantee see www.ledvance.com/guarantee

DISCLAIMER

Subject to change without notice. Errors and omission excepted. Always make sure to use the most recent release.